



3.14

Pressure reducing valve pilot operated

Type 3DR10P...L6X

Size 10
up to 315 bar
up to 120 L/min

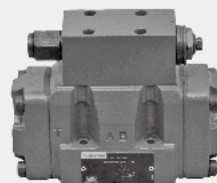

Contents

Function and configuration	02
Ordering code	03
Technical data	03
Characteristic curves	04
Unit dimensions	05

Features

- Porting pattern conforms to DIN 24 340 form A and ISO 4401
- 4 pressure ratings
- 2 adjustment elements
 - Rotary knob
 - Adjustable bolt with protective cap
- Pressure gauge fitting

Function and configurations

The pressure valve type 3DR10P is a pilot operated 3-way pressure reducing valve with pressure limitation in the secondary circuit. It is used for reducing pressure in a hydraulic system.

The pressure reducing valve consists mainly of main valve (1), control spool (2) and pilot control valve (3) with pressure adjustment element (10). At static state, the valves are normally open, fluid flows free from port P to port A. The pressure in port A is applied via the channel (4) to the spool area opposite to the compression spring (9). Fluid also acts on the ball valve (7) of the pilot valve (3) via the throttle orifice (6) and channel (5). Based on the setting value of the spring (11), control piston keeps open, then fluid can flow free from port P to port A, until pressure at port A exceed the setting value of spring(11), and then ball valve (7) is opened. Control piston (2) moves to close

position. When pressure at port A is balanced with setting value at spring (11), pressure reducing is achieved as expected.

If the pressure in port A continuously increases due to external forces, the control spool (2) is moved still further against the compression spring (9). Thus port A is connected to port T via the control lands (8) at the control spool (2). Enough fluid flows to tank to ensure that the pressure does not rise any further.

The pilot oil returns from spring chamber (12) to tank without back pressure via control line (13) to port Y.

A pressure gauge connection (14) makes it possible to monitor the reduced pressure in port A.

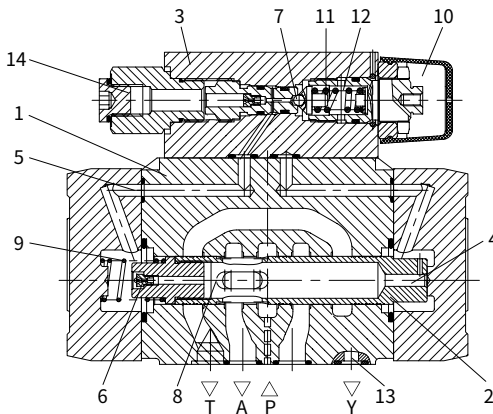

Type 3DR10P5-L6X/...

Symbol:

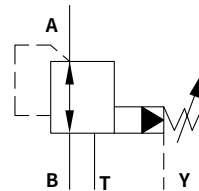

Ordering code

3DR	10	P	-L6X	/	Y	/	*
-----	----	---	------	---	---	---	---

3-way pressure reducing valve

Nominal size 10 =10

Sub-plate mounting = P

Rotary knob =4

Adjustable bolt with protective cap =5

Series L60 to L69 (L60 to L69 series: unchanged installation and connection dimensions) = L6X

Further details in clear text

No code = NBR seals

V = FKM seals

Y= Pilot oil drain external

5 = Max. secondary pressure 50 bar

10 = Max. secondary pressure 100 bar

20 = Max. secondary pressure 200 bar

31.5 = Max. secondary pressure 315 bar

03

Technical data

Fluid	Mineral oil suitable for NBR and FKM seal Phosphate ester for FKM seal		
Fluid temperature range	°C	-30 to +80 (NBR seal) -20 to +80 (FKM seal)	
Viscosity range	mm ² /s	10 to 800	
Degree of contamination	Maximum permissible degree of fluid contamination: Class 9. NAS 1638 or 20/18/15, ISO4406		
Nominal pressure	bar	315	
Max.operating pressure	port P	bar	315
Max.operating pressure	port A	bar	315
Max.operating pressure	port Y	bar	Separate and at zero pressure to tank
Setting pressure	Min.	bar	Dependent on the flow (see curves)
	Max.	bar	50;100;200;315
Max. flow-rate	L/min	120	
Weight	kg	Approx.6.5	

Characteristic curves (Measured at $\vartheta_{oil} = 40^{\circ}\text{C} \pm 5^{\circ}\text{C}$, using HLP46)

P_A -Q Characteristic curve

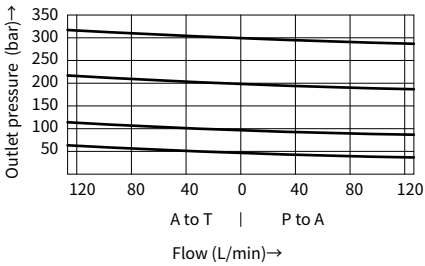

P_{min} -Q characteristic curve

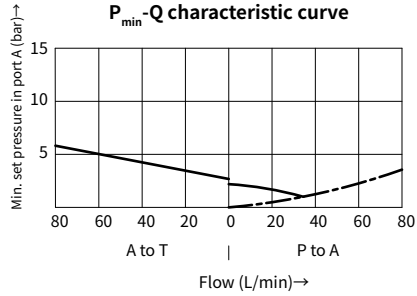

ΔP -Q characteristic curve

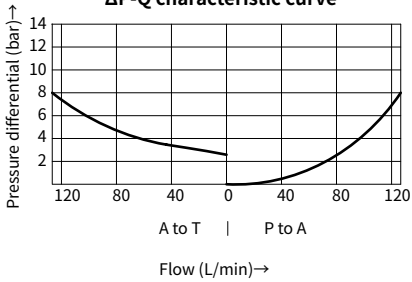

Pilot flow in relation to the main flow

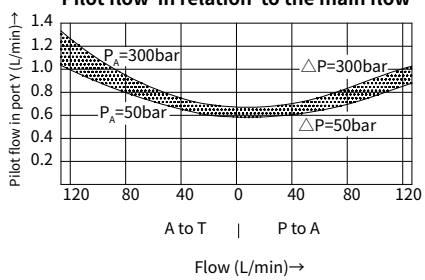

Unit dimensions

(Dimensions in mm)

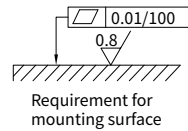
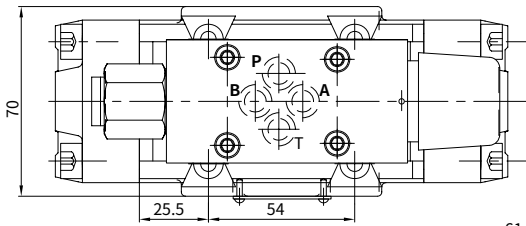
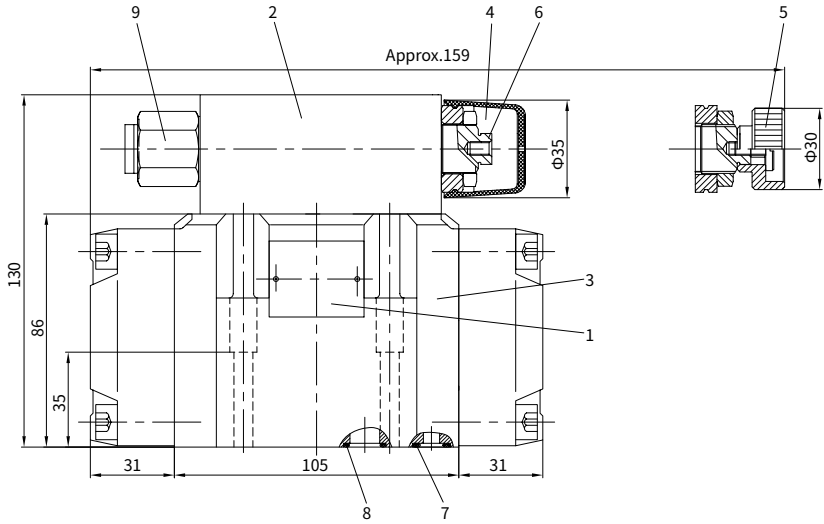

- 1 Name plate
- 2 Pilot control valve
- 3 Main valve
- 4 Adjustment element "5"
- 5 Adjustment element "4"
- 6 Internal hexagon screw S=10
- 7 O-rings 10.82×1.78 (Port X and Y)
- 8 O-rings 12×2 (Ports A2, B2, P2, TA2 and TB2)
- 9 Pressure gauge connection G1/4

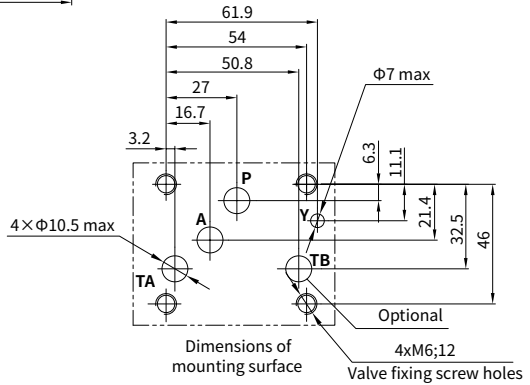

It must be ordered separately, if connection plate is needed.

Type: G535/01(G3/4) G535/02(M27×2)
G536/01(G1) G536/02(M33×2)

Valve fixing screws:

4 pcs GB/T -10.9,
internal hexagon screw
Tightening torque $M_A=15.5$ Nm

China

+86 400 101 8889

America

+01 630 995 3674

Germany

+49 172 3683463

Japan

+81 03 6809 1696



© This brochure can be reproduced, edited, reproduced or transmitted electronically without the authorization of Hengli Hydraulic Company. Due to the continuous development of the product, the information in this brochure is not specific to the specific conditions or applicability of the industry, thus, Hengli does not take any responsibility for any incomplete or inaccurate description.