

4.1

# Throttle and throttle check valve

## Type MG/MK

Sizes 6 to 30  
Up to 315 bar  
Up to 400 L/min



### Contents

Function and configuration	02
Ordering code	02
Technical data	03
Characteristic curves	03
Unit dimensions	04

### Features

- Suitable for direct in-line mounting
- Pressure and viscosity dependent

## Function and configuration

Valve types MG and Mk are throttle and throttle check valves with viscosity and pressure dependent.

### •Type MG (throttle valve)

This valve throttles in both flow directions. Fluid flows through side hole (3) to the throttling orifice (4) formed between the valve body (2) and the adjustable sleeve (1). The cross-section of throttling orifice (4) may be steplessly varied by rotating the sleeve (1).

### •Type MK (throttle check valve)

In throttling direction, the spring (6) and the fluid presses the poppet (5) onto its seat, check valve is blocked. Fluid flows via the side hole (3) to the throttling orifice (4), formed between the valve body (2) and the adjustable sleeve (1).

In the opposite direction, fluid pressure acts on the face of the poppet (5), check valve is opened and fluid flows freely. At the same time, part of the fluid flowing through the annular groove gets self-clearance as the desired effect.

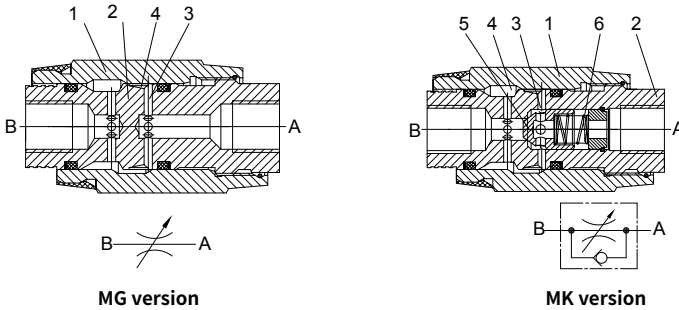

## Ordering code

		G	1 ■	2 /		*
Throttle valve	=MG					Further details in clear text
Throttle check valve	=MK					No code = NBR seals V = FKM seals
Nominal size 6	=6					Threaded connection
Nominal size 8	=8					G thread
Nominal size 10	=10					Metric thread
Nominal size 15	=15					NPTF thread
Nominal size 20	=20					(not suitable for nominal size 15 and 20)
Nominal size 25	=25					SAE straight thread
Nominal size 30	=30					
				1.2 =		1.2 series
		G =				Threaded connection

## Technical data

Size		6	8	10	15	20	25	30
Weight	kg	0.3	0.4	0.7	1.3	2.2	3.6	4.5
Max.operating pressure	bar	315bar, 210bar (NPTF1 1/4, NPTF1 1/2)						
Cracking pressure for type MK	bar	0.5						
Max.flow-rate	L/min	400						
Viscosity range	mm <sup>2</sup> /s	10 to 800						
Fluid temperature range	°C	-30 °C to +80 °C						
Fluid		Mineral oil; Phosphate ester						
Degree of contamination		Maximum permissible degree of fluid contamination: Class 9. NAS 1638 or 20/18/15, ISO4406						

## Characteristic curves (Measured at $\vartheta_{oil}=40^{\circ}C \pm 5^{\circ}C$ , using HLP46)

### $\Delta P$ -Q curves via check valve, with closed throttle (type MK)

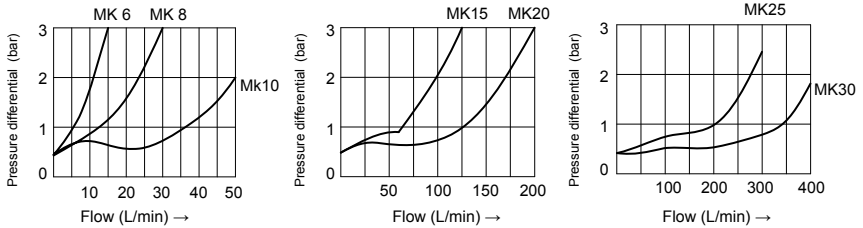

### $\Delta P$ -Q curves via open throttle (type MG and MK)

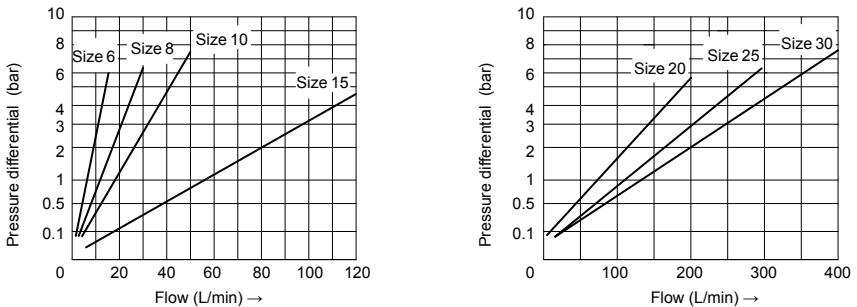

**Unit dimensions** (MK and MG are the same)

(Dimensions in mm)

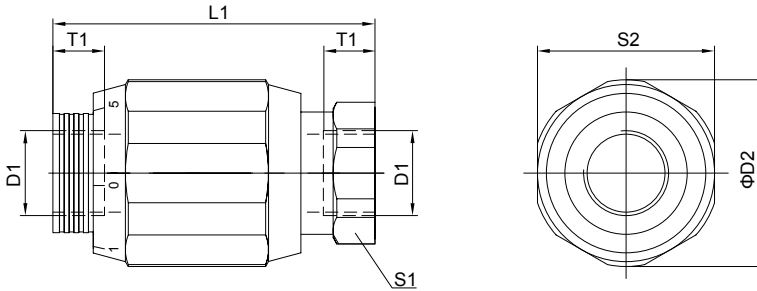

Size	D1				D2	L1	S1	S2	T1
	G	Metric	NPTF	SAE					
6	G1/4	M14×1.5	NPTF 1/4	6SAE (9/16-18)	34	65 (SAE=75)	22	32	12 (SAE=14)
8	G3/8	M18×1.5	NPTF 3/8	8SAE (3/4-16)	38 (SAE=48)	65 (SAE=77)	24 (SAE=30)	36 (SAE=45)	12 (SAE=17)
10	G1/2	M22×1.5	NPTF 1/2	10SAE (7/8-14)	48	80 (SAE=93)	30	46	14 (SAE=20)
15	G3/4	M27×2	—	12SAE (1 1/16-12)	58	100 (SAE=113)	41	55	16 (SAE=22)
20	G1	M33×2	—	16SAE (1 5/16-12)	72	110 (SAE=120)	46	70	18 (SAE=22)
25	G1 1/4	M42×2	NPTF 1 1/4	20SAE (1 5/8-12)	87	130 (SAE=140)	55	85	20 (SAE=22)
30	G1 1/2	M48×2	NPTF 1 1/2	24SAE (1 7/8-12)	93	150 (SAE=160)	60	90	22 (SAE=24)